

TAURUS 700

Mini-dumper 700 kg

Standard Equipment

- ✓ Skip fitted to mount self-loading shovel
- ✓ Sealed wheel bearings to prevent ingress of dirt
- ✓ Hardened driving wheels for longer life
- ✓ STCS (Self Tension Crawler System)
- ✓ Shovel arms with double attachment yoke
- ✓ Hydraulic quick-coupling for shovel system release
- ✓ Steel bearings with greasing points at pivot points
- ✓ Removable engine bonnet for better access for checks, servicing and refuelling
- ✓ Standard 14 L / min flow rate power take-off
- ✓ Exhaust pipe with elbow to discharge towards the ground
- ✓ Foldable footplate kit

Applications

The Taurus 700 mini-dumper is the ideal solution for the transportation and handling of various types of material on site and in places where access is difficult. It is completely at ease on any terrain, including tough slopes, steps and ramps. Two travel speeds ensure maximum operating efficiency even on very large sites. The reduced noise level enhances operator comfort and makes the machine suitable for use even in urban centres.



Engine with reduced noise emissions and mounted on vibration dampers to significantly reduce the amount of vibrations transmitted



The self-loading shovel can transfer all sorts of material, such as rubble, earth, and aggregate, into the skip quickly and safely, with minimum operator effort



Engine options

The Taurus 700 mini-dumper is equipped with a Honda 6 or 8.2 kW petrol engine, with recoil or electric start, or a Yanmar 7.4 kW diesel engine, with electric start, for reduced fuel consumption and longer operating. Taurus 700 is equipped as standard with a hydraulic power take-off providing a flow rate of 14 litres/min. The engine is completely protected and enclosed between fixed side panels and a removable front bonnet.

Tackles any slope

Thanks to the large undercarriage, the large driving sprocket and 4 track rollers per side, Taurus 700 is completely at ease on any terrain, including tough slopes, steps and ramps.

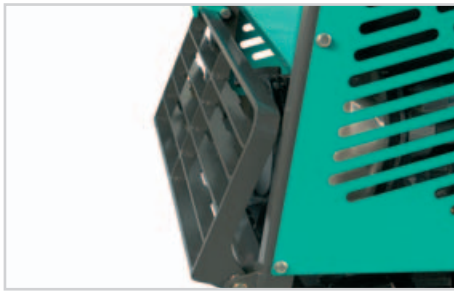

Designed with the operator in mind

The steering handle is mounted on dampers to reduce the vibration transmitted to the arms and upper body, ensuring total operator comfort. Even the structure of the spring-damping footplate prevents vibrations from being transmitted to the body. The footplate conveniently folds out of the way when the machine is operated from the ground to prevent accidental contact with the operator's legs. When the machine is driven with the operator on board, the footplate is automatically locked in the open position to protect it from being closed accidentally.

Simple, intuitive controls

The control console is simple and intuitive. The control lever protection bar is a convenient armrest for the operator, while the control levers are connected directly to the control valve to ensure an accurate, progressive response.



250 L Concrete mixer kit

The perfect accessory for mixing small batches of concrete for construction and transporting them to the place of use. Excellent for renovation projects calling for small quantities of concrete in various positions, also widely spaced.



Loading bed with opening sides

The version with loading bed reaches a surface of 1240 x 1290 mm. The loading bed is suitable for transporting construction materials and bulky materials, transporting and unloading materials for the consolidation of roads, with the possibility of unloading even partially in the needed points without having to carry out any positioning maneuvers.



Front levelling blade

The front blade is a multifunctional interchangeable accessory suitable for levelling soils and conglomerates. The possibility of being inclined on both sides by 30° and the horizontal tilting with spring return make it particularly suitable for clearing of snow. The accessory is equipped with two sliding supports which enable it to be detached from the mini-dumper without the need for additional lifting equipment.

TAURUS 700

Mini-dumper 700 kg

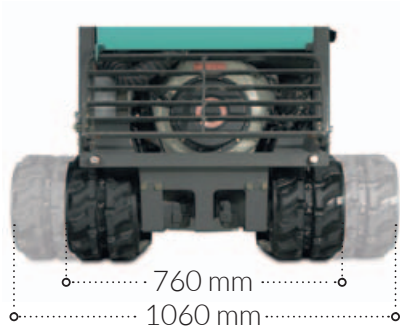

Extendable undercarriage



Honda hour meter/rev counter kit

Standard on Taurus 700 petrol and diesel versions. This kit enables the operator to view the engine rpm when the engine is running. When the engine is stopped, the hour meter is displayed.

Accessory assembly-disassembly kit

Specific optional equipment for assembly and disassembly of accessories in the absence of appropriate lifting systems.

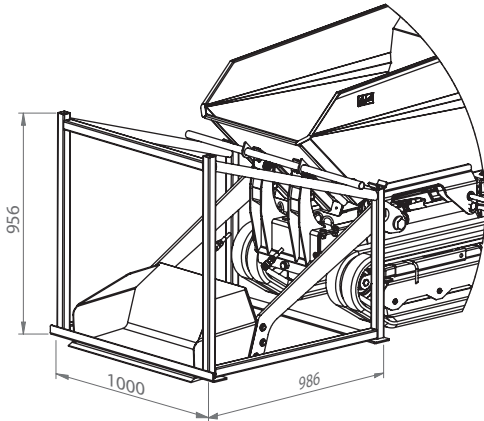

Hi-Flow Kit

Additional kit of hydraulic components, which allows an increased one-way flow rate of around 26 l/min for auxiliary hydraulic services. When fitted with this kit, Taurus 700 can be used when stationary with a wide range of tools: hand operated hydraulic auger, demolition hammer, hydraulic drill, pump for muddy water.

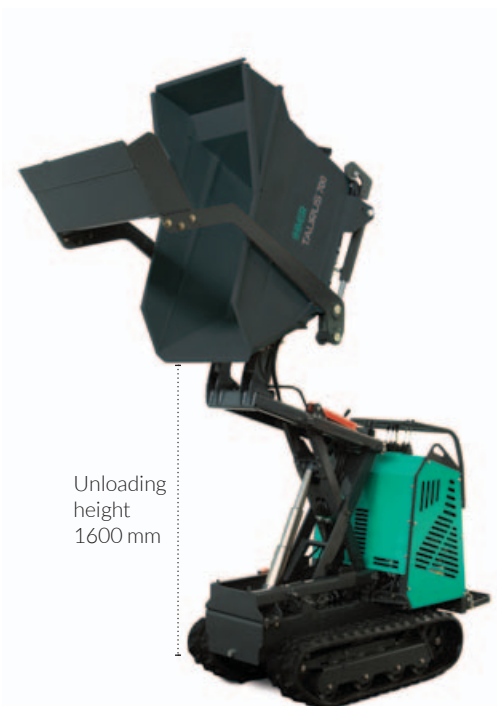

HT model with high discharge

The Taurus 700 HT model is ideal for transporting and handling materials. The "hi-tip" kit helps to empty the tipping bucket from above where desired, directly on the truck and into specific skips.

TAURUS 700 / tipping bucket with self-loading shovel

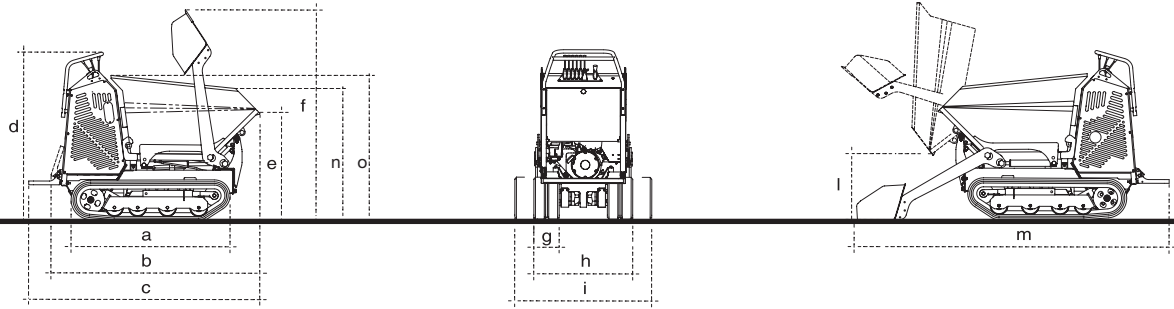

DIMENSIONS (mm)

a	b	c	d	e	f	g	h	i	l	m	n	o
1253	1647	1824	1336	863	1671	180	760	1060	519	2484	1050	1150

TAURUS 700 / loading bed with opening sides

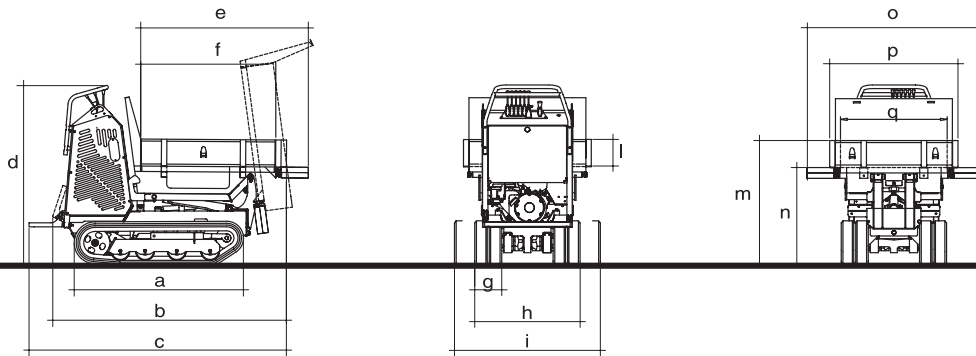

DIMENSIONS (mm)

a	b	c	d	e	f	g	h	i	l	m	n	o	p	q
1250	1730	1906	1336	1240	1000	180	760	1060	200	925	724	1290	960	790

TAURUS 700 / concrete mixer with self-loading shovel

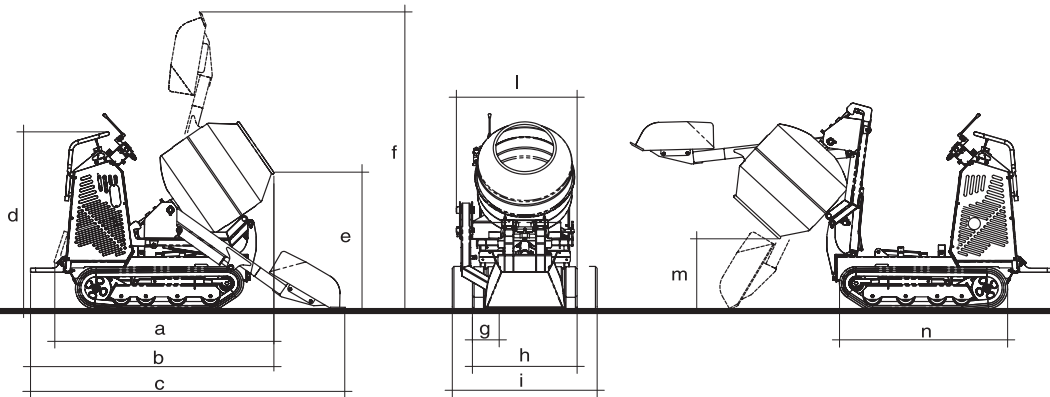

DIMENSIONS (mm)

a	b	c	d	e	f	g	h	i	l	m	n
1633	1814	2346	1336	1036	2230	180	760	1060	900	539	1250

TAURUS 700 / levelling blade

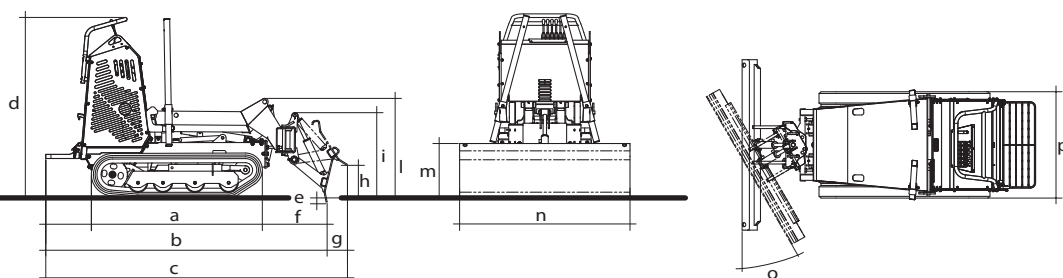

DIMENSIONS (mm)

a	b	c	d	e	f	g	h	i	l	m	n	o	p
1253	2064	2213	1234	28	475	149	239	625	730	402	1250	30°	760/1060

TAURUS 700

Mini-dumper 700 kg

TAURUS 700 HT / tipping bucket with self-loading shovel

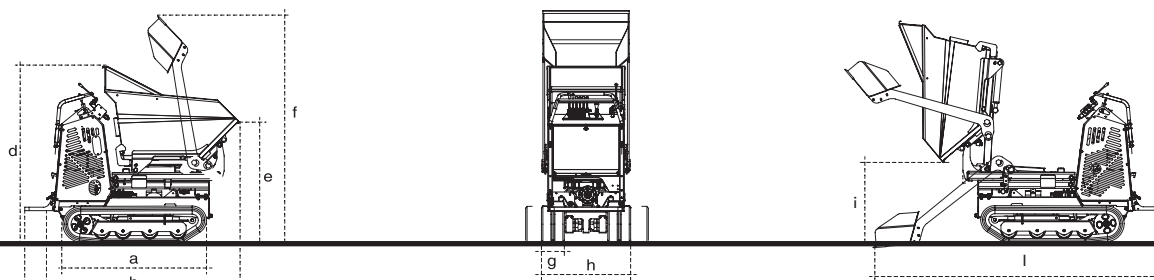

DIMENSIONS (mm)

a	b	c	d	e	f	g	h	i	l
1250	1647	1878	1552	1060	2036	180	760/1060	707	2590

TAURUS 700 HT / raised tipping bucket with self-loading shovel

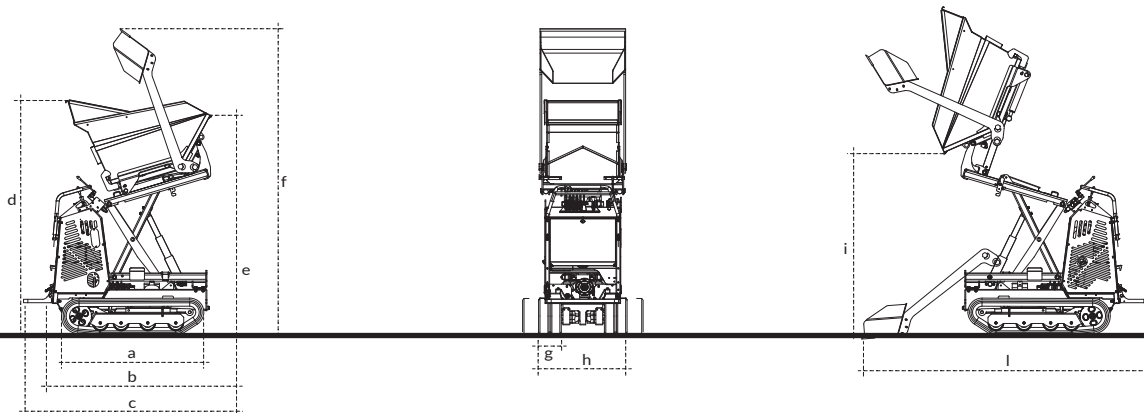

DIMENSIONS (mm)

a	b	c	d	e	f	g	h	i	l
1250	1647	1824	2070	1940	2702	180	760/1060	1580	2305

	TAURUS 700			TAURUS 700 HT
	Petrol - 8 HP	Petrol - 11 HP	Diesel - 10 HP	Petrol - 11 HP Diesel - 10 HP
	C-B8 CE-B8 CP-B8 CPE-B8 A-B8 AE-B8	C-B11AE CE-B11AE CP-B11AE CPE-B11AE A-B11AE AE-B11AE	C-D10AE CE-D10AE CP-D10AE CPE-D10AE A-D10AE AE-D10AE	CE-B11AE CPE-B11AE CPE-D10AE
Engine	Honda GX270 petrol			Honda GX390 petrol / Yanmar L100 diesel
Engine power	kW / rpm	6 / 3600	8.2 / 3600	7.4 / 3600
Operating load	kg	700	700	700
Skid capacity	mc	0.33	0.33	0.33
Hydraulic extension (in models with extendable undercarriage)	mm	760 / 1060	760 / 1060	760 / 1060
Speed	km / h	2.3 / 3.2	2.3 / 3.2	2.3 / 3.2
Max allowed slope when empty (guide with operator on the ground, where applicable)		20° - 36% *	20° - 36% *	20° - 36% *
Max allowed slope when loaded (guide with operator on the ground, where applicable)		11° - 20% *	11° - 20% *	11° - 20% *
Concrete mixer kit (drum capacity/yield capacity)	l	250 / 190	250 / 190	250 / 190
Loading bed dimensions with closed sides l/w/h (with opening sides l/w)	mm	990/790/200 (1240/1290)	990/790/200 (1240/1290)	990/790/200 (1240/1290)
Controls		DCS (Direct Control System)	DCS (Direct Control System)	DCS (Direct Control System)
Hydraulic tank capacity	l	17	17	17
Traction motor		Orbital	Orbital	Orbital
Batteries	V / Ah	-	12 / 60	12 / 60
Machine weight with tipping bucket (with extendable undercarriage)	kg	488 (538)	508 (558)	530 (580)
Machine weight with tipping bucket and self-loading shovel (with extendable undercarriage)	kg	558 (608)	578 (628)	600 (650)
Machine weight with loading bed with opening sides (with extendable undercarriage)	kg	505 (555)	525 (575)	547 (597)

(*) Variable based on the configuration

CODE	DESCRIPTION
TAURUS 700 PETROL HONDA GX270 8HP	
1108022	TAURUS 700 C-B8 Honda GX270 petrol engine, tipping bucket
1108002	TAURUS 700 CP-B8 Honda GX270 petrol engine, tipping bucket and self-loading shovel
1108088	TAURUS 700 A-B8 Honda GX270 petrol engine, loading bed with opening sides
TAURUS 700 PETROL HONDA GX270 8HP extendable undercarriage	
1108089	TAURUS 700 CE-B8 Honda GX270 petrol engine, tipping bucket, extendable undercarriage
1108090	TAURUS 700 CPE-B8 Honda GX270 petrol engine, tipping bucket and self-loading shovel, extendable undercarriage
1108091	TAURUS 700 AE-B8 Honda GX270 petrol engine, loading bed with opening sides, extendable undercarriage
TAURUS 700 PETROL HONDA GX390 11HP electric start	
1108077	TAURUS 700 C-B11AE Honda GX390 petrol engine, electric start, tipping bucket
1108001	TAURUS 700 CP-B11AE Honda GX390 petrol engine, electric start, tipping bucket and self-loading shovel
1108078	TAURUS 700 A-B11AE Honda GX390 petrol engine, electric start, loading bed with opening sides
TAURUS 700 PETROL HONDA GX390 11HP electric start, extendable undercarriage	
1108086	TAURUS 700 CE-B11AE Honda GX390 petrol engine, electric start, tipping bucket, extendable undercarriage
1108021	TAURUS 700 CPE-B11AE Honda GX390 petrol engine, electric start, tipping bucket and self-loading shovel, extendable undercarriage
1108085	TAURUS 700 AE-B11AE Honda GX390 petrol engine, electric start, loading bed with opening sides, extendable undercarriage
TAURUS 700 DIESEL YANMAR L100N 10HP electric start	
1108068	TAURUS 700 C-D10AE Yanmar L100N diesel engine, electric start, tipping bucket
1108000	TAURUS 700 CP-D10AE Yanmar L100N diesel engine, electric start, tipping bucket and self-loading shovel
1108072	TAURUS 700 A-D10AE Yanmar L100N diesel engine, electric start, loading bed with opening sides
TAURUS 700 DIESEL YANMAR L100N 10HP electric start, extendable undercarriage	
1108073	TAURUS 700 CE-D10AE Yanmar L100N diesel engine, electric start, tipping bucket, extendable undercarriage
1108074	TAURUS 700 CPE-D10AE Yanmar L100N diesel engine, electric start, tipping bucket and self-loading shovel, extendable undercarriage
1108075	TAURUS 700 AE-D10AE Yanmar L100N diesel engine, electric start, loading bed with opening sides, extendable undercarriage
TAURUS 700 HT high discharge, electric start, extendable undercarriage	
1108084	TAURUS 700 HT CE-B11AE Honda GX390 petrol engine, electric start, tipping bucket, extendable undercarriage, HI-TIP high discharge
1108023	TAURUS 700 HT CPE-B11AE Honda GX390 petrol engine, electric start, tipping bucket and self-loading shovel, extendable undercarriage, HI-TIP high discharge
1108076	TAURUS 700 HT CPE-D10AE Yanmar L100N diesel engine, electric start, tipping bucket and self-loading shovel, extendable undercarriage, HI-TIP high discharge

Accessories

CODE	DESCRIPTION
1108158	Self-loading shovel for concrete mixer TAURUS 700
1108011	250L concrete mixer and self-loading shovel kit TAURUS 700
1108155	Hi-Flow kit TAURUS 700
1108010	Accessories mounting kit TAURUS 700

Accessories TAURUS 700 HT

CODE	DESCRIPTION
1108155	Hi-Flow kit TAURUS 700
1107720	HI-TIP accessories mounting kit TAURUS 700 HT

CODE	DESCRIPTION
1108156	Front levelling blade kit TAURUS 700
1108160	Tipping bucket TAURUS 700
1108161	Self-loading shovel TAURUS 700
1107721	Loading bed with opening sides TAURUS 700

CODE	DESCRIPTION
1108157	Self-loading shovel TAURUS 700 HT
1108015	250L concrete mixer and self-loading shovel kit TAURUS 700 HT